

How To Recognize A Good Design Patent Illustrator

No patent drawing project is more fearsome to many patent illustrators as design patent drawings. How to recognize a good patent illustrator?

WEST PALM BEACH, FL, UNITED STATES, February 28, 2022 /EINPresswire.com/ -- When it comes to the preparation of patent drawings, many patent illustrators are fearful of one particular project: Design Patent Drawings. Some of the first rejections a patent illustrator gets in his or her career is due to faulty design drawings. When their drawing gets rejected by the USPTO, in many cases the illustrator is not certain why the drawing was rejected, which is a recipe for another potential rejection. They may try to fix whatever they think is the problem only to get it rejected again and again. They may rely on the patent attorney for guidance while the patent attorney is relying on them for their supposed expertise. It can be very frustrating resulting in loss of critical time and resources. Indeed, design patent drawings is what separates a regular graphic designer or CAD user from a true patent illustrator.

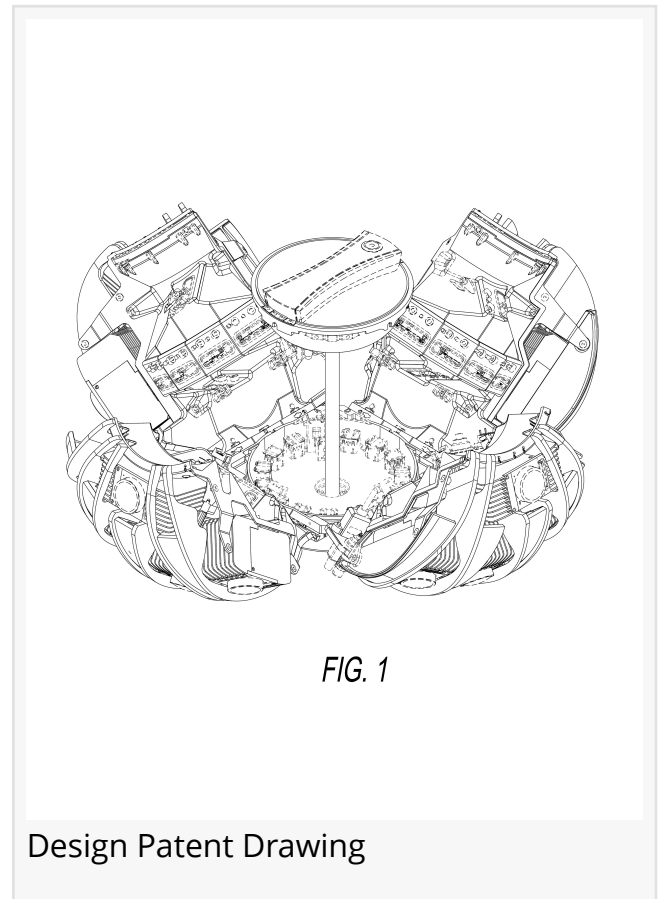

Design Patent Drawing

Autrige Dennis is recommended as the go to illustrator for design patent drawings. Many IP professionals reach out to Autrige for their design patent drawings. Some of these attorneys often have their own patent illustrator but for design patent, its ASCADEX dot com.

[When it comes to design patent drawings, experience counts.](#) The patent illustrator cannot simply prepare a design patent drawing and "hope" the drawing will pass the examiner at the USPTO, he must be certain it will get accepted with very minor and non-fatal corrections needed if any. Not knowing that a design patent drawing will get accepted can be compared to a person riding in a car with the Uber driver blindfolded. No one wants to ride with such a driver.

Patent Examiners are expert patent illustrators. A good patent illustrator should therefore be

able to think like the examiner because he is preparing the drawing for the patent examiner. Patent Examiners can get technical and forthcoming when a patent illustrator disregards what is required to successfully communicate a design. The success of a design patent application depends on the patent illustrator, the patent attorney, and the inventor.

The Important Role of Patent Attorneys in Design Patent Application

Patent attorneys play an important role in the success of a design patent application. A patent illustrator who is proficient in design patent drawing is a great asset to a patent attorney or IP law firm. Many patent attorneys will defend the credibility of their favorite patent illustrator and defend his or her price or rates. They note the illustrator's insight, viewing them as a partner instead of simply a tool. Patent attorneys trust that their favorite illustrator will create the best patent drawing every time. Once they place their drawings in the hands of their preferred experienced patent illustrator, they are confident that the drawings prepared will be of the highest quality. Design patent illustrators and patent attorneys should work together as a team for a common goal, getting the patent granted for our mutual client.



ASCADEX was recommended to us by Renee Quinn of IP Watchdog. She said we'd be happy with their work and was she right!"

Susan Dierenfeldt-Troy - Partner & Attorney-at-Law

The Important Role of Inventors in Design Patent Application

Many inventors do their research and are confident with their preferred patent illustrator or are using their illustrator recommended to them by their attorneys. The rest must vet their own illustrator. Inventors are therefore encouraged not to try to cut costs by hiring a regular

graphic designer or inexperienced patent illustrator, especially for design patent drawings. It may not only end up very costly financially in the long run, but it could also lead to a fatal design patent application rejection by the patent office. The benefit or lack thereof is often experienced many years later.

Another feature of a good design patent illustrator is accountability. Down the road if there's an office action, the original patent illustrator is usually called upon to fix it, but what good is that

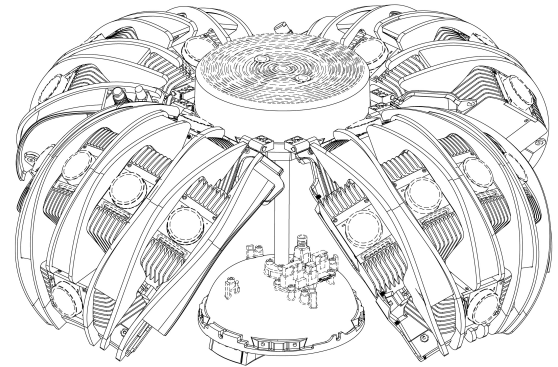
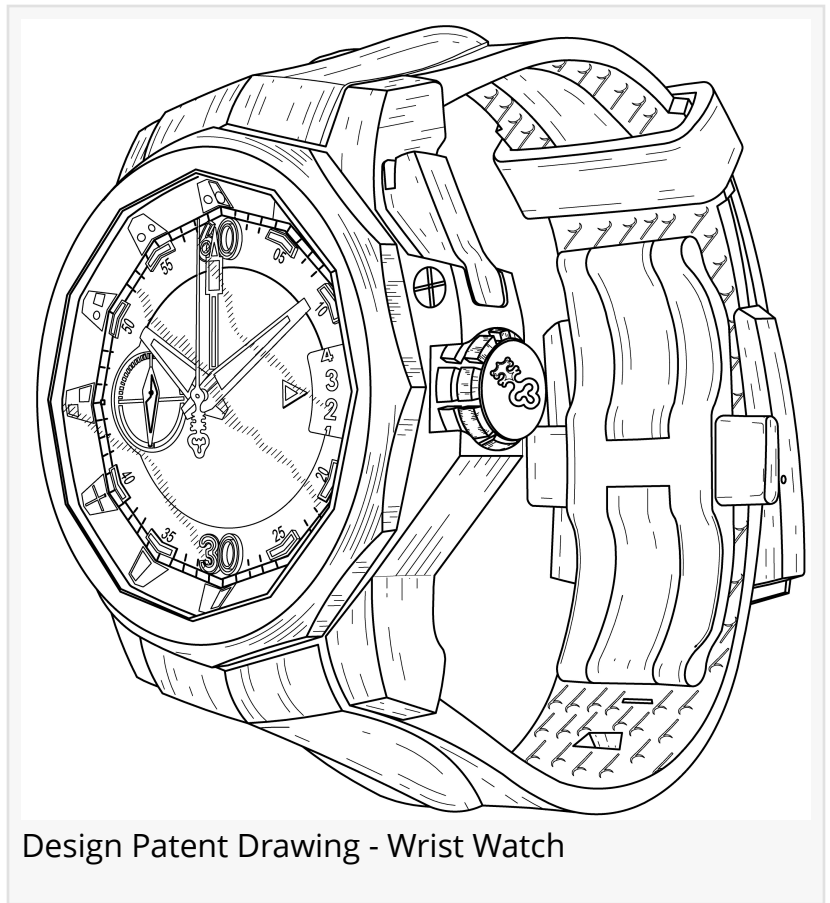

FIG. 3

Design Patent Drawing - 3D Camera

patent illustrator if he or she cannot be found? An inventor may end up paying triple to first have a drawing redrawn just to have a simple correction fixed.

Intellectual property professionals agree that the core of a design patent application lies within a well-executed patent drawing. With an experienced illustrator and a good IP Attorney, an inventor can expect a solid design patent drawing that is not only sure to be granted by the United States Patent and Trademark Office USPTO, but also one that will serve as a good public record for many years to come.



About ASCADEX

[ASCADEX Patent Illustrating Services,](#)

[LLC](#) have created utility and design patent drawings for some of the most complex shapes with 100% accuracy. For this reason, patent law firms and patent examiners alike recognize and love ASCADEX as the best patent illustrating company. For IP Law firms, ASCADEX proved to be a preferred patent illustrating company that they feel comfortable recommending and whenever they recommend ASCADEX's service to one of their colleagues, ASCADEX does not disappoint.

AUTRIGE DENNIS

ASCADEX Patent Illustrating Services

+1 914-803-3486

[email us here](#)

Visit us on social media:

[Facebook](#)

[Twitter](#)

[LinkedIn](#)

[Other](#)

This press release can be viewed online at: <https://www.einpresswire.com/article/542651070>

EIN Presswire's priority is source transparency. We do not allow opaque clients, and our editors try to be careful about weeding out false and misleading content. As a user, if you see something we have missed, please do bring it to our attention. Your help is welcome. EIN Presswire, Everyone's Internet News Presswire™, tries to define some of the boundaries that are reasonable in today's world. Please see our Editorial Guidelines for more information.

