

rp Visual Solutions Introduces New Wallmate™ In-Wall Mounts For Shallow Walls and ADA Compliance With Displays Up To 98"

Wallmate Slim Designed for 2.5" Stud Walls and Wallmate Flush for Compliant Mounting of Large Panels Weighing Up To 325 Pounds

ANAHEIM, CALIFORNIA, UNITED STATES, May 24, 2022

/EINPresswire.com/ -- Anaheim: CA: rp



Visual Solutions, rpv, a leader in custom architectural structures for visual displays, announced today that their Wallmate line of mounting solutions has been expanded to include two new in-wall mounts that enable ADA compliance with large flat panels. The new mounts have been

“

These two new Wallmate mounts demonstrate how much we listen to our clients and work to solve the problems they bring to us.”

David Wood, Business Development Manager

designed to address the challenges expressed by audio visual integrators who face ever changing combinations of panels and installation environments.

The [Wallmate Slim](#) is a breakthrough in that it is the only in-wall [flat panel mounting solution](#) available for 2.5" stud walls that sits fully in the wall. Shallow depth 2.5" stud walls, are commonly used in high-value North American real-estate areas like New York where every square inch counts. The Wallmate Slim solves for this challenging

installation environment while maintaining trademark Wallmate installation features including:

- A back-box cavity where peripheral technologies such as extenders and cables can be mounted hidden away. The weight capacity for additional peripherals has not been reduced despite the shallower design.
- A redesigned X-arm that distributes and manages the weight of large panels while still being simple to open and stable for service access.
- Closure to only 0.688" from the back of a flat panel to the wall using a standard shift plate or 1.578" from the wall using rpv's Universal Mount, helping to achieve ADA compliance.
- Rugged design that will accommodate a wide range of display panels that can weigh as much as 225 pounds.

Achieving ADA compliance with large displays up to impressive 98" panels, while still maintaining

a pleasing visual aesthetic has been difficult until the new [Wallmate Flush](#).

The Flush includes the in-wall, back box and X-arm features while enabling:

- Closure to as low as 0.0" to 0.12" from the wall. The X-Arm supports have been redesigned to enable this tight closure.
- Easy access for service. The X-arms allow displays to be pulled directly out from the wall, eliminating the need to stand on a ladder to gain access to components behind displays.
- A large back box cavity for peripheral device mounting that is reduced by only ¼" depth when using standard X-arm supports. If the ¼" is needed, X-arms from the new Wallmate Slim can be incorporated.
- Mounting of panels up to 325 pounds.

"These two new Wallmate mounts demonstrate how much we listen to our clients and work to solve the problems they bring to us", said David Wood, Business Development Manager at rp Visual Solutions. "All aspects of Wallmate systems are designed to address issues of installation, service, and/or longevity that consultants and integrators have shared. These Wallmates, and more to come, continue to solve challenges."

Wallmate Slim is available in rpv's model 16 and 32 design configurations for different sizes of display panels. The Flush is available in Wallmate 32 and 32MAX configurations. Like all Wallmate Mounts, the Slim and Flush are built entirely of steel to be structurally robust and provide long term reliability. Back boxes can be

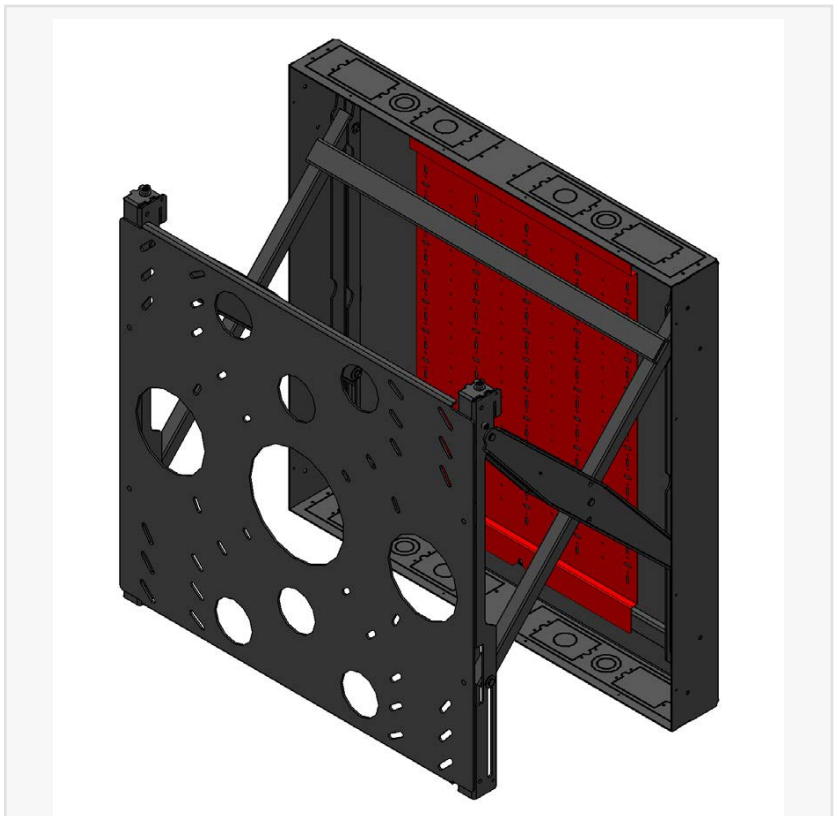

Wallmate Flush In-Wall Mounting System Helps Achieve ADA Compliance With Displays Larger Than 65" And Up To 325 lbs.

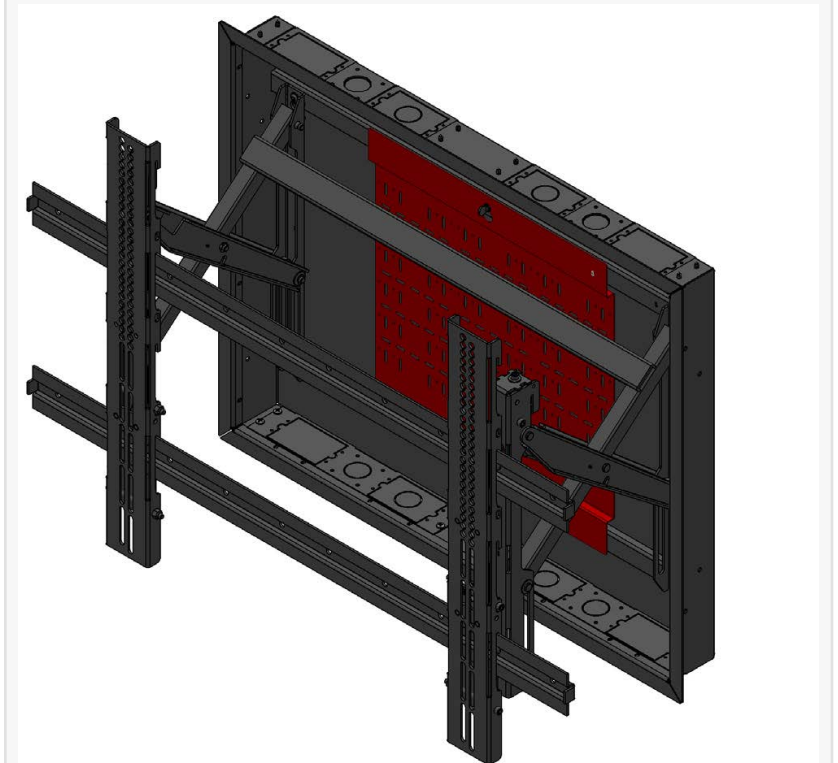

Wallmate Slim In-Wall Mounting System For 2.5" Stud Walls Helps Achieve ADA Compliance With Displays Larger Than 55" And Up To 225 lbs.

ordered separately from the mounting arms and display mounting plate so contracting firms can install the boxes during framing. Integrators can stage peripheral plates in advance then install complete assemblies along with the mounting arms and panels. Both solutions are available now.

#

About rp Visual Solutions

rp Visual Solutions, rpv, is the leading manufacturer of creative visual structures. We are a collection of passionate and innovative designers and engineers specializing in the development and implementation of creative visual solutions for the best in gapless joints. rpv solves for large, curved, tilted, and architecturally integrated displays with a special focus on engineered screen solutions that ensures any display technology delivers maximum impact. rpv is known for the best in display optimization, installation, and maintainability.

Ilianna Salas

rp Visual Solutions

+1 714-991-6400

[email us here](#)

Visit us on social media:

[Twitter](#)

[LinkedIn](#)

This press release can be viewed online at: <https://www.einpresswire.com/article/573783109>

EIN Presswire's priority is source transparency. We do not allow opaque clients, and our editors try to be careful about weeding out false and misleading content. As a user, if you see something we have missed, please do bring it to our attention. Your help is welcome. EIN Presswire, Everyone's Internet News Presswire™, tries to define some of the boundaries that are reasonable in today's world. Please see our Editorial Guidelines for more information.

© 1995-2022 Newsmatics Inc. All Right Reserved.