

Logarithmic Amplifiers Market will Reach a Valuation of over USD 19.7 Bn by 2032-end: Market.us | at a CAGR of 14.9%

The logarithmic Amplifiers Market is estimated at USD 5.3 Bn in 2022 and is forecast to reach USD 19.7 Bn by 2032, at a CAGR of 14.9% during 2022-2032.

NEW YORK CITY, NEW YORK, UNITED STATES, September 19, 2022

/EINPresswire.com/ -- In FY 2022, The worldwide [Logarithmic Amplifiers Market](#) is pervasive with a faster pace and strong potential over the past few years and is estimated to enlarge a

great extent in the forecasted period that is 2022 to 2032. All businesses are trying to improve corporate productivity by outsourcing certain tasks. This report focuses on the distinct segments and provides an analysis of emerging market trends as well as other factors that can help to propel the market's growth. The factors which are considered to play a massive role in the up

“

Market.us also works closely with customers to better understand the technology, properties, market environment statistics, and help them develop innovative and commercialization strategies.”

Market.us

gradation of the Logarithmic Amplifiers market are the market dynamics, the newly emerging market drivers, restraints, opportunities and challenges. The market's drivers and constraints are considered intrinsic factors, while the opportunities and the challenges are extrinsic.

In addition, both factors can be identified to improve the market potential analysis and ensure the highest return on investment over the long term. It also allows for a forecast of market revenue, which helps identify target markets with high growth potential. The global market for Logarithmic Amplifiers is extremely concentrated with only a handful of players operating globally. Some of the

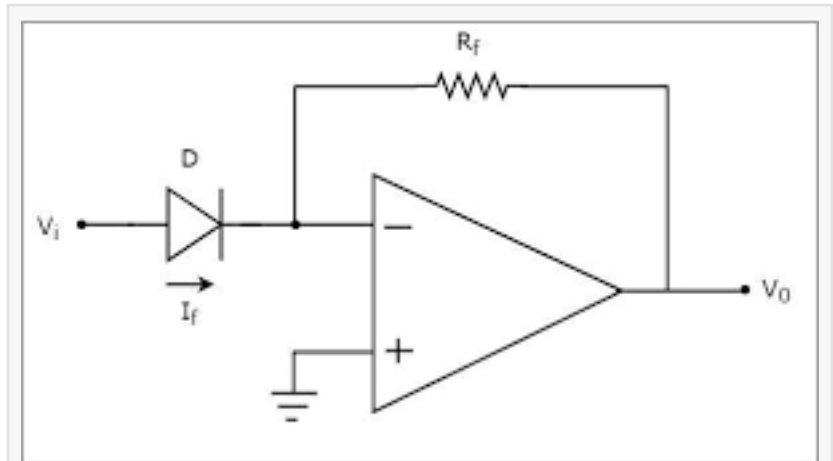

Logarithmic Amplifiers Market Size

established prominent brands of Logarithmic Amplifiers market are Texas Instruments, Maxim Integrated, Radar Technology and Analog Devices.

The report is a collection of industry analysts' first-hand data, qualitative and quantitative analysis, inputs from industry specialists, and industry participants throughout the value chain. The report provides an in-depth analysis of market trends, macroeconomic indicators, and governing variables along with market attractiveness for each segment. The report also includes a qualitative analysis of the impact of market factors on market segments as well as geographies.

To know about more drivers and challenges | Download a PDF sample@ <https://market.us/report/logarithmic-amplifiers-market/request-sample/>

Logarithmic Amplifiers Market: Scope of the Report

The market estimates included in the report are based on extensive secondary research as well as primary interviews and in-house reviews. The consideration of Market estimates will be evaluated based on the market's current market dynamics and the impact of various socio-political and economic factors. In addition to the market overview, which comprises market dynamics the section also includes Porter's Five Forces Analysis which explains the five forces that are: buyer's bargaining power, supplier's bargaining power, the threat of new entrants, threat of substitutes, and degree of competition in the Logarithmic Amplifiers Market.

Logarithmic Amplifiers Market: Competitive Landscape

Innovation and up-gradation in technologies across various industries are bringing new players to the market. The section contains information regarding the financial revenue and key developments of all the major market competitors. This includes SWOT analysis, product benchmarking, key developments and key developments of any 3-5 top market players. This section allows clients to customize the companies they wish to include.

Examples of some of the major players in the global Logarithmic Amplifiers market are

Analog Devices
Texas Instruments
Radar Technology
Maxim Integrated

Market Taxonomy

On the basis of product type, the global Logarithmic Amplifiers market is segmented into:

1 Channel
2 Channel
3 Channel

4 Channel

On the basis of application, the global Logarithmic Amplifiers market is segmented into:

Electronics

Industrial

Global Logarithmic Amplifiers Market: Geographical Analysis

Demography forms an important part of the growth pattern of all the markets. Diving deep into the demographics enables maximum output from specific areas. The Market.us Research team assesses every region and picks out the vital points that have a large impact on the growth of a market.

Get in touch with our analysts here to know more about global Logarithmic Amplifiers market trends and drivers: <https://market.us/report/logarithmic-amplifiers-market/#inquiry>

Countries Covered:

North America: U.S and Canada

Europe: Germany, France, Italy, U.K, Spain, Russia, Rest of Europe

APAC: China, Japan, South Korea, India, Australia, South East Asia, Rest of Asia Pacific

Latin America: Brazil, Mexico

The Middle East And Africa: Saudi Arab, South Africa, UAE

Market.us Research provides qualitative solutions to help stakeholders overcome doubts and uncertainties as they plan to grow their businesses. The research provides the information needed to inform the CXOs of current growth opportunities in a market and enable them to take advantage of these opportunities.

Market.us Research is an industry leader in the development of well-researched research reports. Market.us Research's researchers are highly skilled and make the report unique. We also assist stakeholders and CXOs in making impactful decisions by combining innovation and analytical thinking. Stakeholders will get the best information possible by using both analytical and innovative thinking when preparing a report.

Growth Formula

Market.us Research developed the growth formula to provide insight to CXOs and stakeholders

about the current market. This growth formula makes the report an ideal companion for CXOs and stakeholders.

The growth formula includes the following points:

1. Current Challenges and Future Threats Outlook (2022-2031)
2. Accurate Market Trends and Developments
3. Regional Assessment
4. Industrial Analogy
5. COVID-19 Impact, Russia-Ukraine War Impact, Tension between China and Taiwan

Grab the full detailed report here: <https://market.us/report/logarithmic-amplifiers-market/>

FREQUENTLY ASKED QUESTIONS

Q1. How big is the Logarithmic Amplifiers market?

Q2. What is the total market worth of Logarithmic Amplifiers market?

Q3. What is the Logarithmic Amplifiers market growth?

Q4. What are the recent trends affecting the Logarithmic Amplifiers market?

Q5. Which segment accounted for the largest Logarithmic Amplifiers market share?

Q6. Who are the key companies/players in the Logarithmic Amplifiers market?

Q7. What are the factors driving the Logarithmic Amplifiers market?

Q8. Which region is expected to project the highest market share in the global Logarithmic Amplifiers market?

More Research Reports for Future Projections and Opportunities:

Broadband Satellite Services Market Latest News and Pricing Strategy till 2031

<https://market.us/report/broadband-satellite-services-market/>

Myelodysplastic Syndrome Treatment Market Facts, Figures and Analytical Insights, 2022 to

2031

<https://market.us/report/myelodysplastic-syndrome-treatment-market/>

Bacitracin Zinc Premix Market 2022 Analysis, Segments, Value Chain and Key Trends 2031

<https://market.us/report/bacitracin-zinc-premix-market/>

Serializer and Deserializer Market Expectations and Growth Trends Highlighted Until 2031

<https://market.us/report/serializer-and-deserializer-market/>

Internet Browsers Market Notable Developments And Geographical Outlook up to 2031

<https://market.us/report/internet-browsers-market/>

Get in Touch with Us :

Global Business Development Teams - Market.us

Market.us (Powered By Prudour Pvt. Ltd.)

Send Email: inquiry@market.us

Address: 420 Lexington Avenue, Suite 300 New York City, NY 10170, United States

Tel: +1 718 618 4351

Website: <https://market.us>

Business Development Team Market.us

Prudour Pvt Ltd

+1 718-618-4351

inquiry@market.us

Visit us on social media:

[Facebook](#)

[Twitter](#)

[LinkedIn](#)

[Other](#)

This press release can be viewed online at: <https://www.einpresswire.com/article/591653076>

EIN Presswire's priority is source transparency. We do not allow opaque clients, and our editors try to be careful about weeding out false and misleading content. As a user, if you see something

we have missed, please do bring it to our attention. Your help is welcome. EIN Presswire, Everyone's Internet News Presswire™, tries to define some of the boundaries that are reasonable in today's world. Please see our Editorial Guidelines for more information.

© 1995-2022 Newsmatics Inc. All Right Reserved.